

RM 002 Fastening system

The RM 002 fastening system for guiding rails has been specially designed and analyzed for crane rails. It can also be successfully used for railway tracks. It is very strong, reliable, and has compact dimensions. It can be used for the construction of tracks of any type, regardless of the size of wheel sets and the type of drive.

TECHNICAL DATA:

Max side load 140 kN

Lateral adjustment 10 mm

Bolt M20 cl 8,8

Tightening torque 175 Nm

Steel grade St52-3

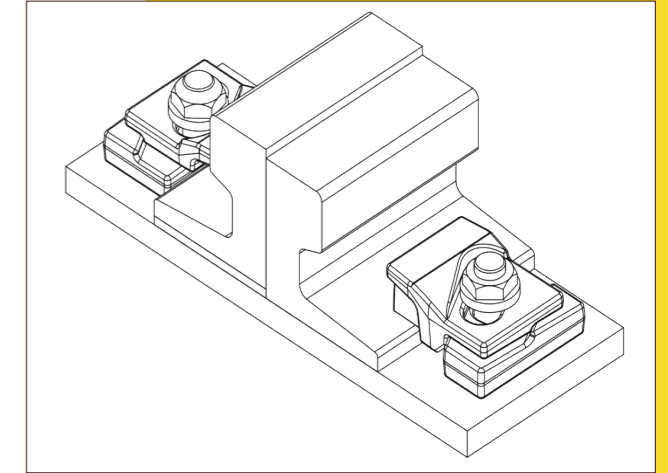

1. Nut M20 DIN 934
2. Washer M20 DIN 7889
3. Upper element of the mount with elastomeric attachment:
short – used in conjunction with a flexible rubber pad
long – without a rubber pad
4. Special bolt M20
5. Lower element to be welded

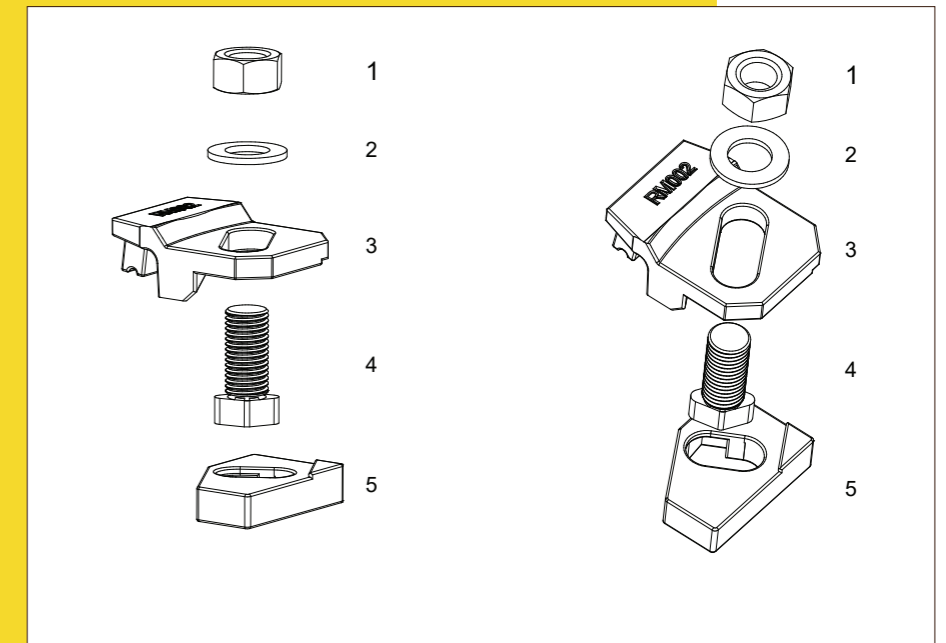

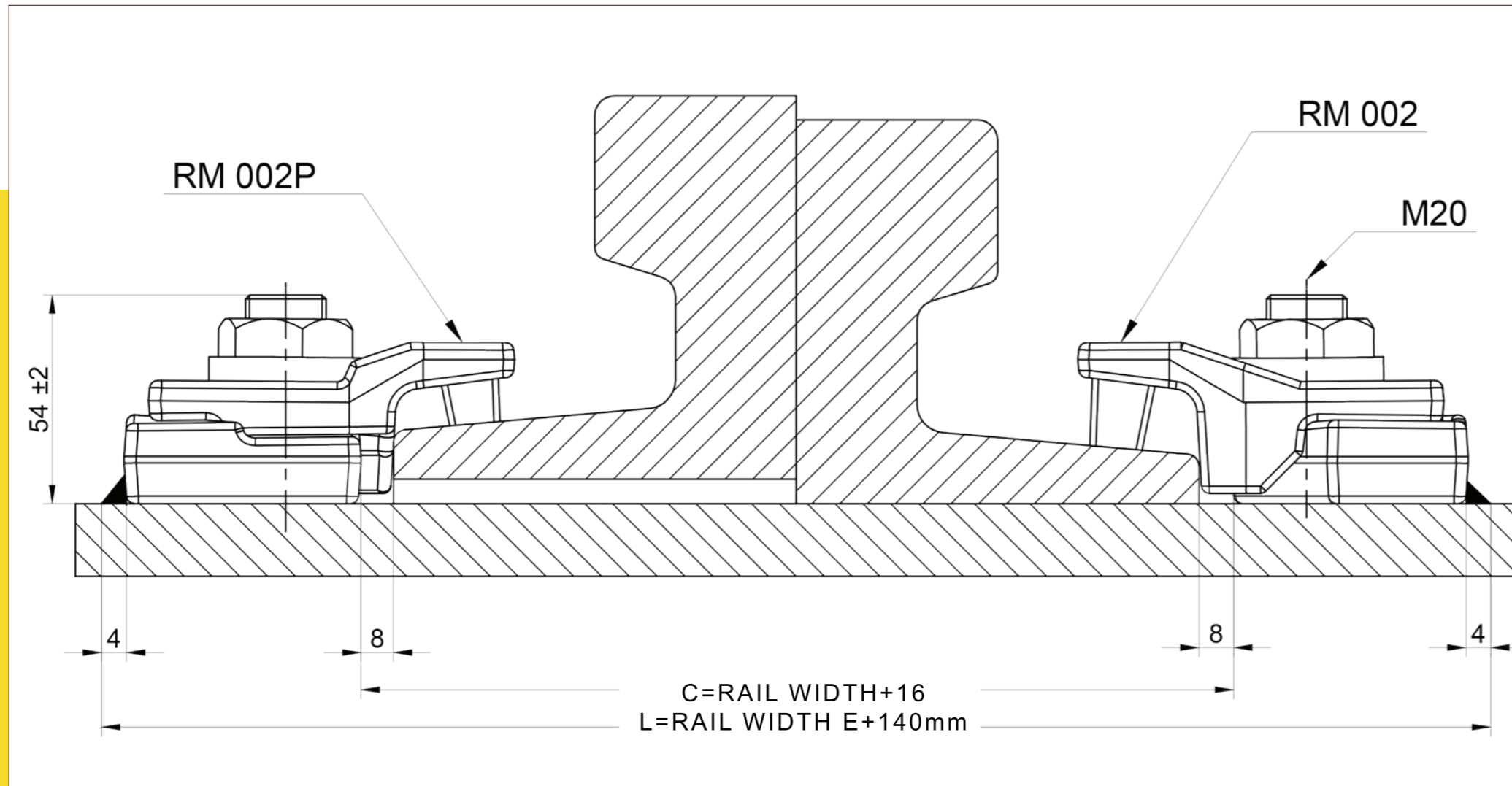

Clip installation

RM002 / RM002P

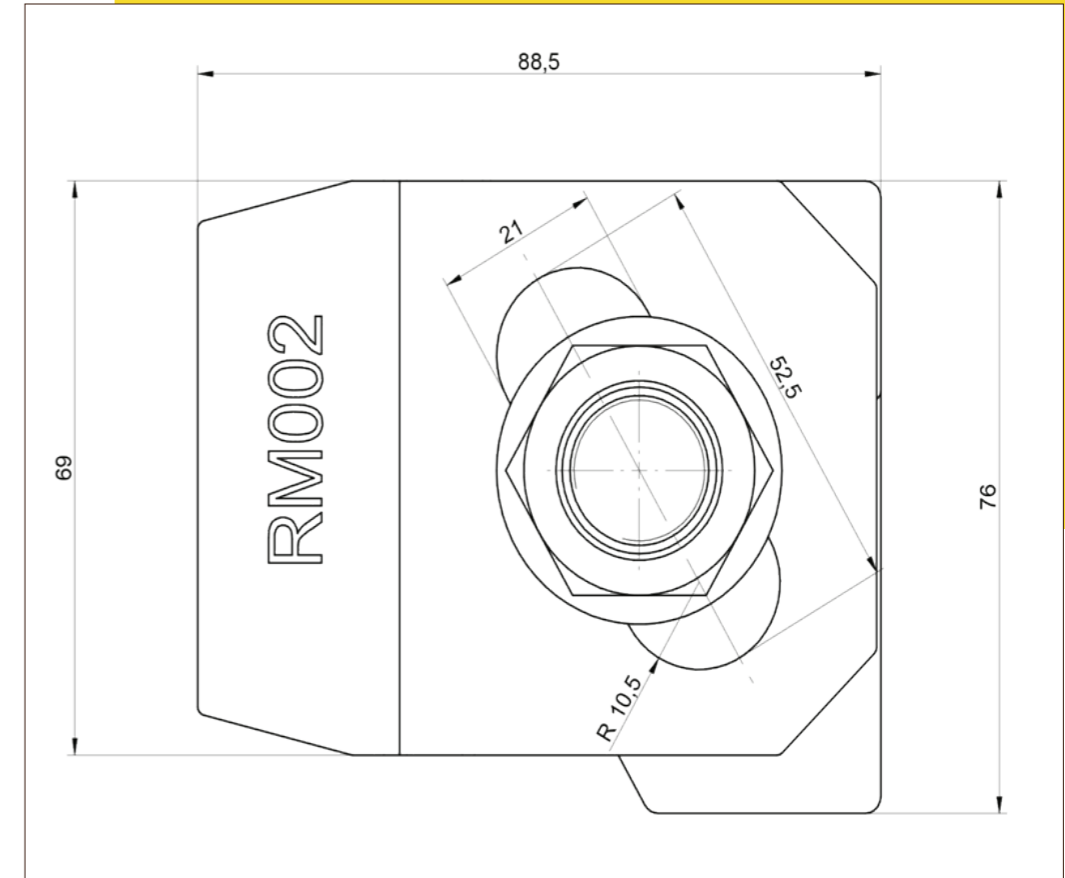
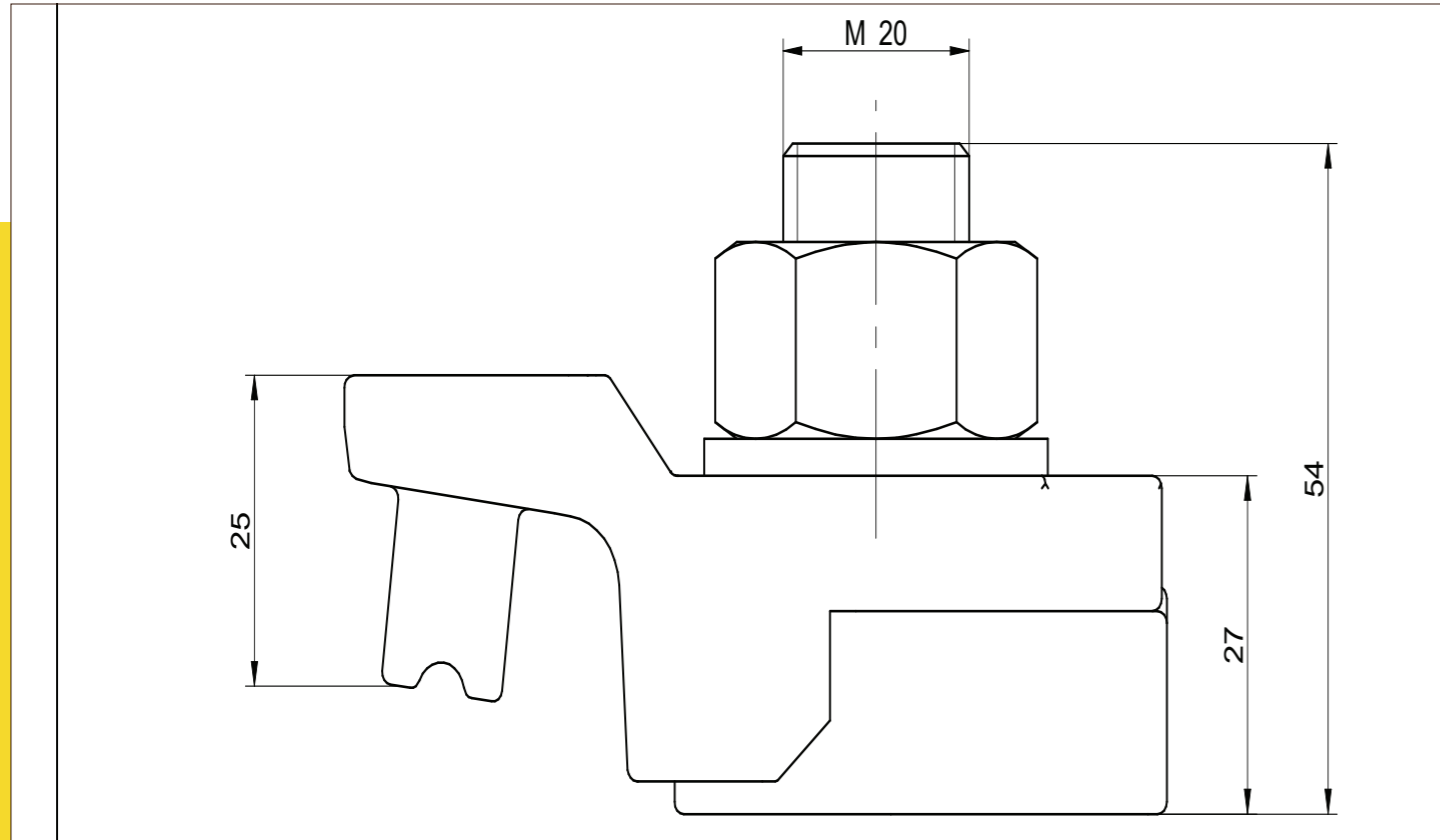

RM002 – clip with long attachment,
Used without the elastomer pad

Tolerance ± 2 mm

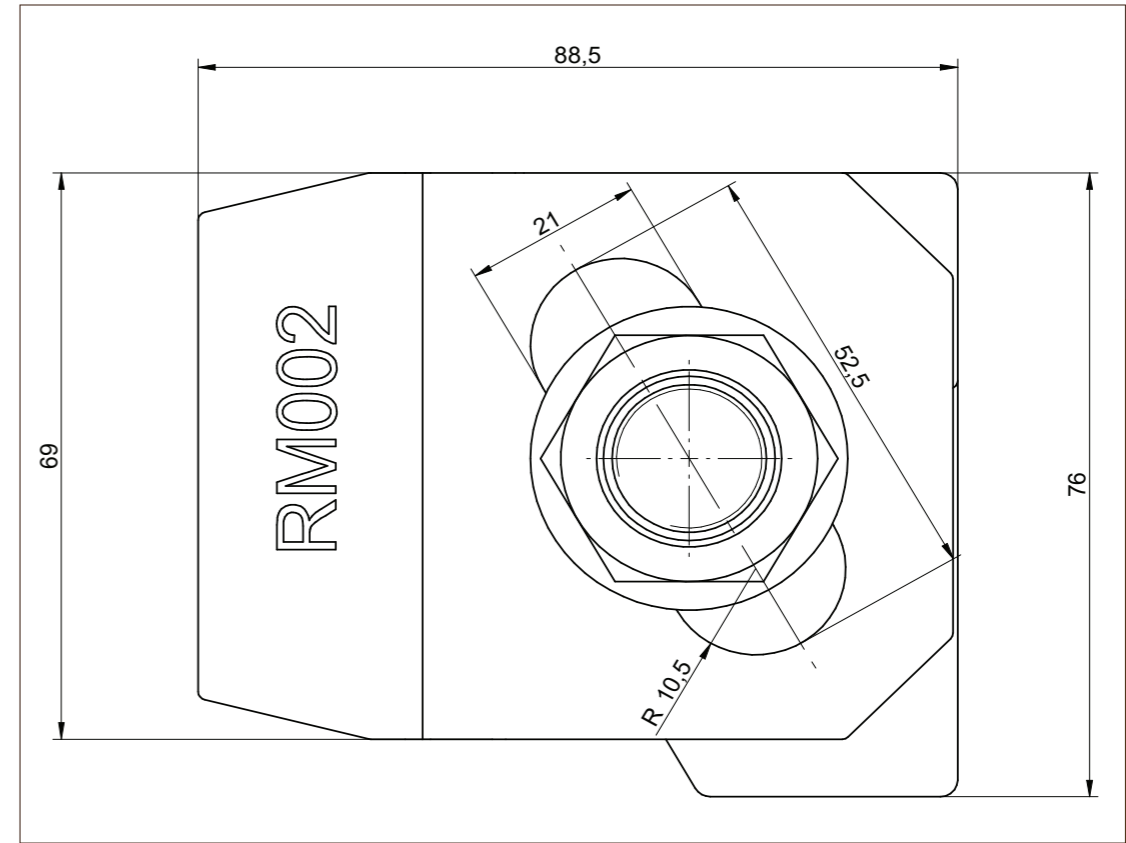
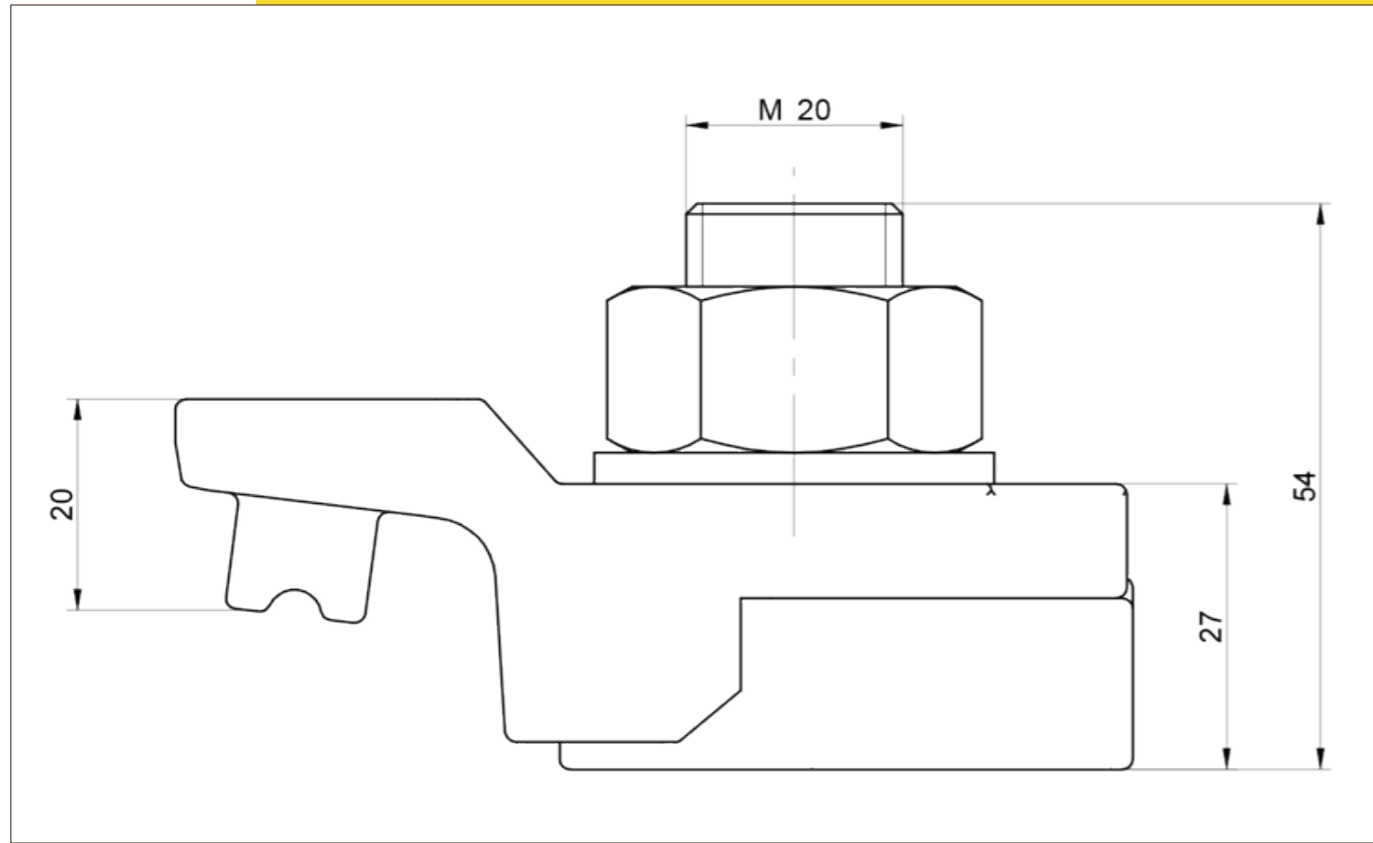

RM002P – clip with short elastomer attachment
– used in conjunction with a flexible rubber pad

WELDABLE RAIL CLIP RM002 / RM002P

					Catalogue number	
Rail type	A mm	B mm	Rail flange width mm E	Weight kg/m	Without the elastic pad	With the flexible elastic pad
A 65	65	75	175	43.10	002	002P
A 75	75	85	200	56.20	002	002P
A 100	100	95	200	74.30	002	002P
A 120	120	105	220	100.00	002	002P
A 150	150	150	220	150.30	002	002P
R 104	63.5	127	127	51.59	002	002P
CR 105	65.1	131.8	131.8	52.09	002	002P
CR1035	76.2	146	131.8	66.97	002	002P
CR 171	101.6	152.4	152.4	84.83	002	002P
MRS 87A	101.6	152.4	152.4	86.80	002	002P
CR 175	102.4	152.4	152.4	86.80	002	002P
MRS 125	120	180	180	125.00	002	002P
46 E4	65	145	135	46.90	002	002P
49 E1	67	149	125	49.39	002	002P
50 ES	67	148	135	49.90	002	002P
54 E1	70	159	140	54.77	002	002P
60 E1	72	172	150	60.21	002	002P

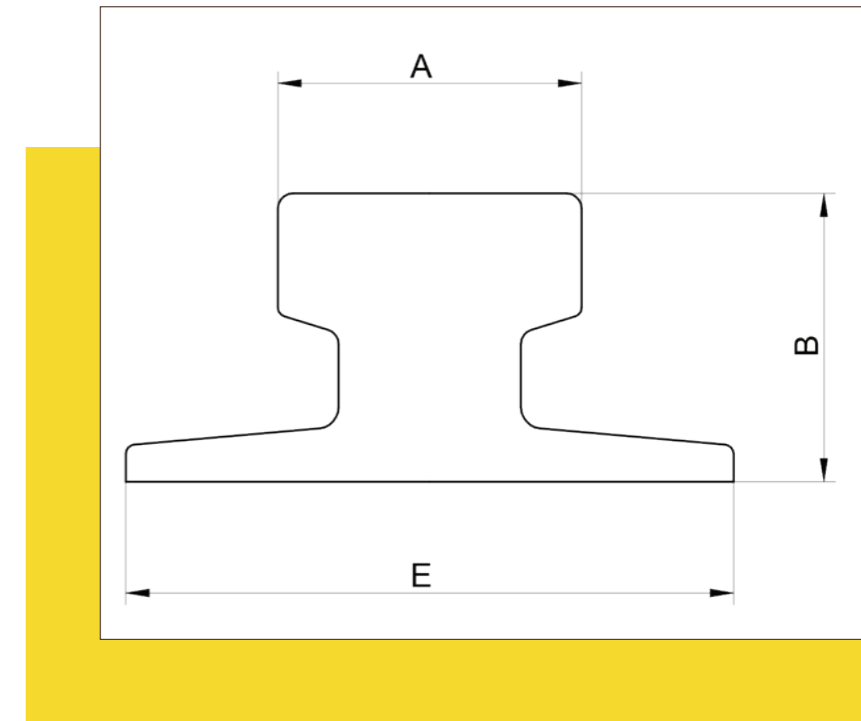

Clamps can be used with different types of rails than those in the table. Full offer of every type of rail is available on request. Products and technical info can be changed without notice

Base parameters:

- Flexible mounting of rails with or without rubber cushioning; the use of a flexible rubber pad additionally reduces noise and dampens railway vibrations. System consists of two cooperating elements enabling easy longitudinal adjustment;
- Two parts of the clamp are connected by a bolt and a flange nut.
- Elastomeric overlay on the top clamp increases the tolerance of the rail support structure, reduces stress, and allows for better rail fastening;
- Welding the bottom part of the clamp facilitates installation onto a steel beam or anchor plates (without the need for drilling).
- The fastening system has been successfully used worldwide in the most demanding conditions.

Rubber pad is made with a synthetic elastomer.

The middle layer has additional steel sheet reinforcement.

Allows to its grooved surface, the Pad underlay provides excellent, even adhesion to the rail surface. It is completely resistant to water, oil, ozone, grease, and UV.

It is used in the construction of tracks for cranes and other equipment moving on rails.

It has a high degree of shape recovery and protects crane mechanisms, thus extending their service life.

Technical data of the pad:

Shore hardness - 75 ± 5

Maximum load- 12,7 N/mm²

Strain – 255% (200% after ageing)

Work temperature – -30 do +110 °C

Vibration dampening – 45-50%

Noise reduction (dbA) – 12%

Deflection – 5% (20% after ageing)

Installation manual

Base of the clamp is made with weldable steel.

Connection can be made using MMA welding with low hydrogen electrodes such as AWS E7018 or E7028 or using MIG welding.

The fillet weld should have 4mm around the base, with the exception of the side closest and parallel to the rail.

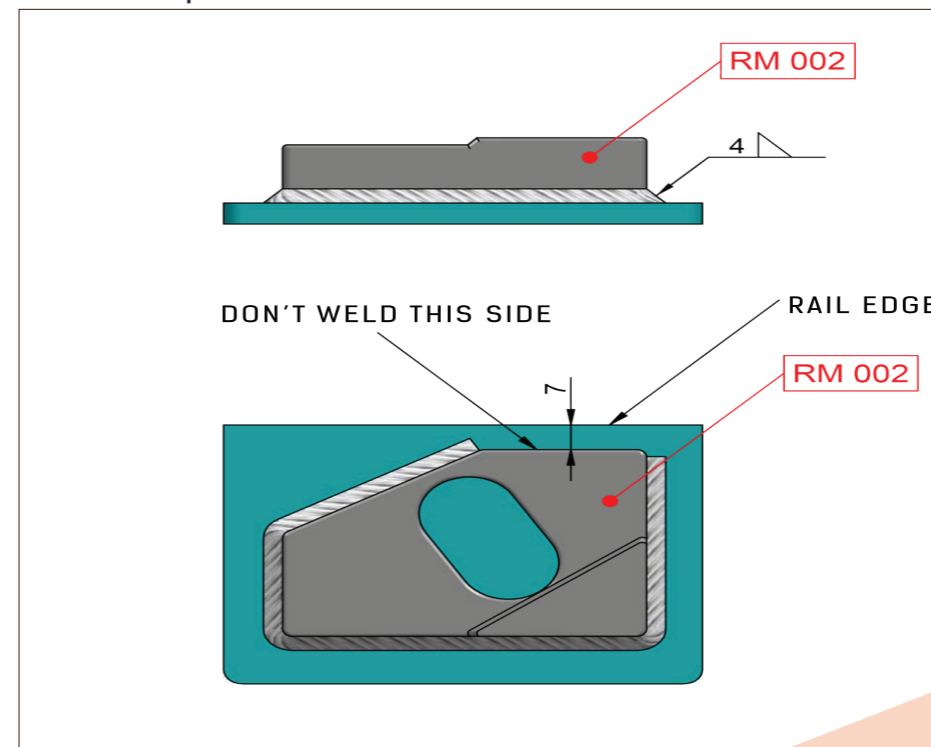

RM002 / RM002P