

Crane rail pad RAY PAD

www.rm-intgroup.com



Crane rail PAD

- is a synthetic elastomer article for heavy-duty crane runways placed between a rail and a supporting framework.

Rail pad is produced of different widths depending on the type of the rail it's applied. Standard pad length is identical to standard length of rails and is 12m.

Technical information:

Shore hardness	75 ± 5
Maximum tensile strength	17,7 MPa
Elongation	255 % (200 % after aging)
Operational temperature	- 30 + 110 °C
Vibration reduction	45-50 %
Noise reduction (dbA)	12 %
Constant deflection	<5% (<20% after aging)

Fundamental properties:

- Reduces noise and constructive vibratory action
- Absorbs shocks, compensates contact between rail and base, ground and structure
- Rail pad RP guarantees firm adherence due to wavy surface
- Rail pad is highly resistant towards water, oils, ozone, greasing substances and corrosion
- Rail pad distributes load from a wheel on broad flat surface reducing pressure that can occur on spots.
- Rail pad is reinforced with a metal plate from inside. It increase resistance to crushing and broadening
- Rail pad reduces frequency or sometimes even necessity of crane rail or track maintenance
- Rail pad protects crane mechanism extending frame, axis and wheels operation period

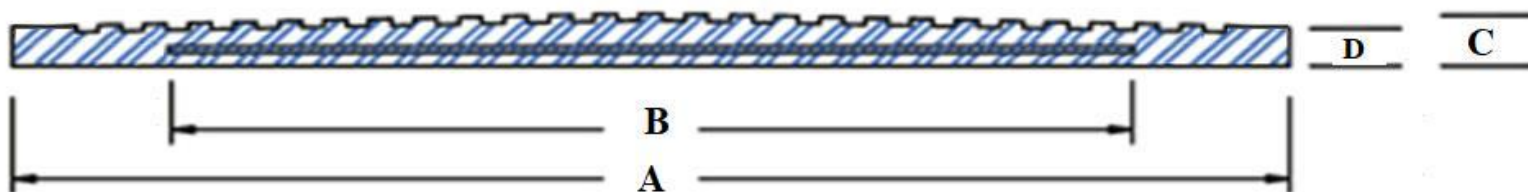

Type	Dimensions, mm				Weight kg / 1 m	Rail type (example)	Width of rail base, mm
	A	B	C	D			
RP80	80	50	7	6	0,830		
RP85	85	50	7	6	0,970		
RP100	100	80	7	6	1.350		
RP120	120	90	7	6	1,550	A45	125
RP130	135	100	7	6	1,670		
RP145	145	100	7	6	1,850	A55	150
RP170	170	130	7	6	2,090	A65	175
RP190	195	155	7	6	2,350	A75 A100	200 200
RP210	215	170	7	6	2,670	A120 A150	220 220
RP315	315	265	7	6	4,350		

Besides full-scale production rail pad can be produced of a unique width as well as in accordance with orders, custom-made and for mounting at the location only.
Technical changes reserved.

INSTALLATION INSTRUCTIONS:

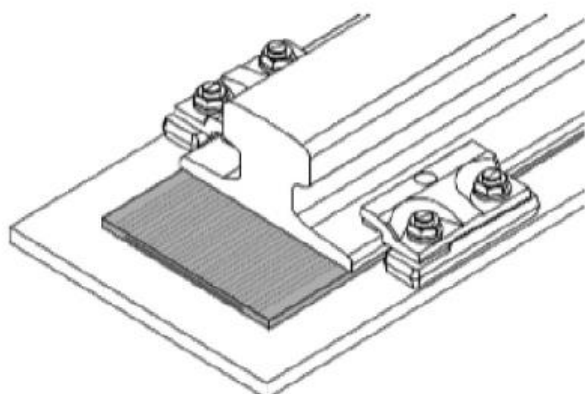

First and utmost the rail pad should conform to chosen rails. Rail pad can be used in and outdoors. Top surface of the rail should be free of oils, thick and slippery materials. They can cause rail pad damage. The pad should be placed on bearing surface gapless wavy surface up. Pads should be placed in full compliance with lower rail edges to cover top parts all over.